



Solar Tech

Author: Joicelyn D. Henry

Introduction

This project encompasses the development of a portable solar charger for laptop computers.

Solar cells are very useful in powering space vehicles such as satellites, telescopes etc. They also power water heating systems.

The use of solar panel systems has become increasingly popular due to the financial savings they offer.

The main goal is to provide laptop users, mainly the students of T.A. Marry show Community College, with a renewable source of energy without incurring the high cost of electricity.

Definition of Problem

High costs of electricity bills

Lack of outlets in school to charge computers

Group sessions badly affected by lack of internet access and mobile power connection.

Solutions Identified

Increasing outlets for students to charge laptops.

Building a fully equipped booth for students to effectively carry out their activities while connected with internet access.

Exploring renewable energy sources like wind, water, sun. However, most of these energy sources are difficult to harness.

Justification of chosen Solution

The increase in outlets can and will lead to an increase in electricity consumption.

Harnessing the sun's energy using solar panels is more efficient to install in urban areas like schools, home and businesses.

Solar power is the most viable option when developing a solution that is cost effective and satisfies mobile uses in devices.

Limitations or Challenges

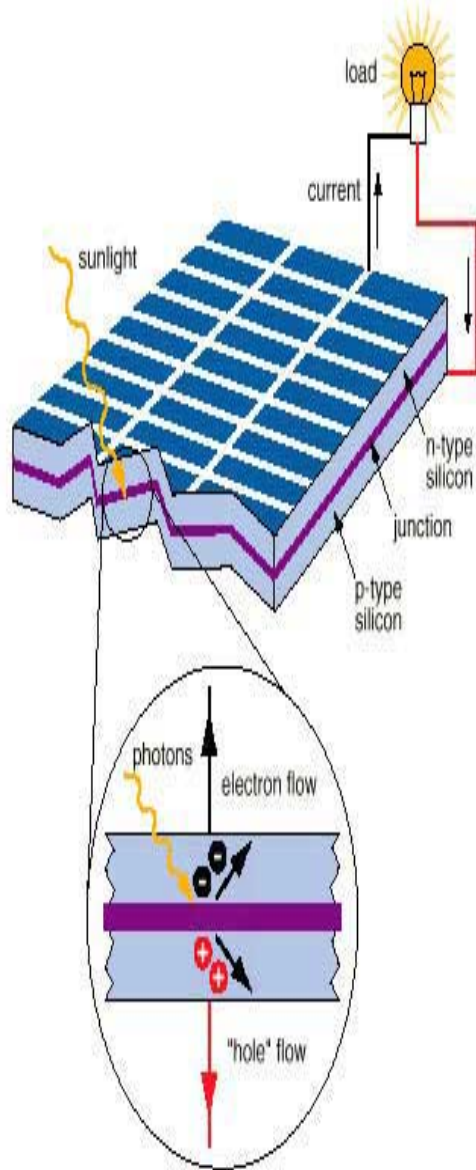

Initial cost of the equipment.



Requires a large surface area constantly exposed to the sun.



Clouds and pollution can degrade the efficiency of photovoltaic cells.

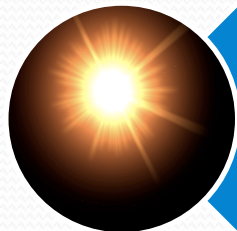

Solar energy is only useful when the sun is shining.

Benefits of Project

Social Benefits:

Protects the environment by being environmentally friendly

Wireless users can take advantage of charging their laptop while in wireless hotspot areas.

Economic (\$\$\$) Benefits:

Reduce cost of electricity consumption

They truly help to reduce the depletion of those resources we can't replace.

Affordable reasonable price

Sources of Funding

- Equipment and materials were bought from:

Personal savings

\$\$\$

Parental support.

Donations

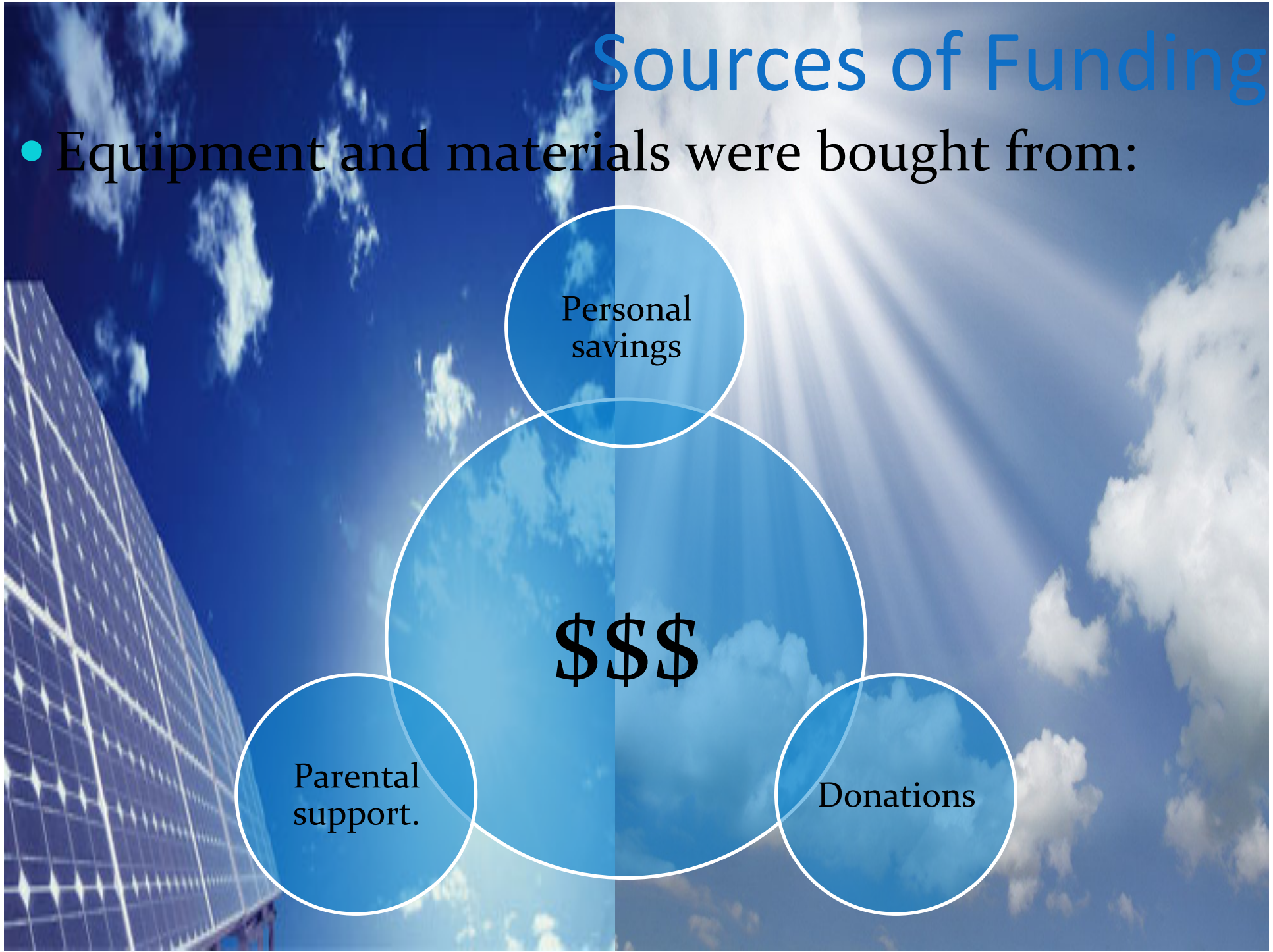

Costing of Project

- Amount Budgeted: USD 500.00
- Actual cost of project: USD 350.00

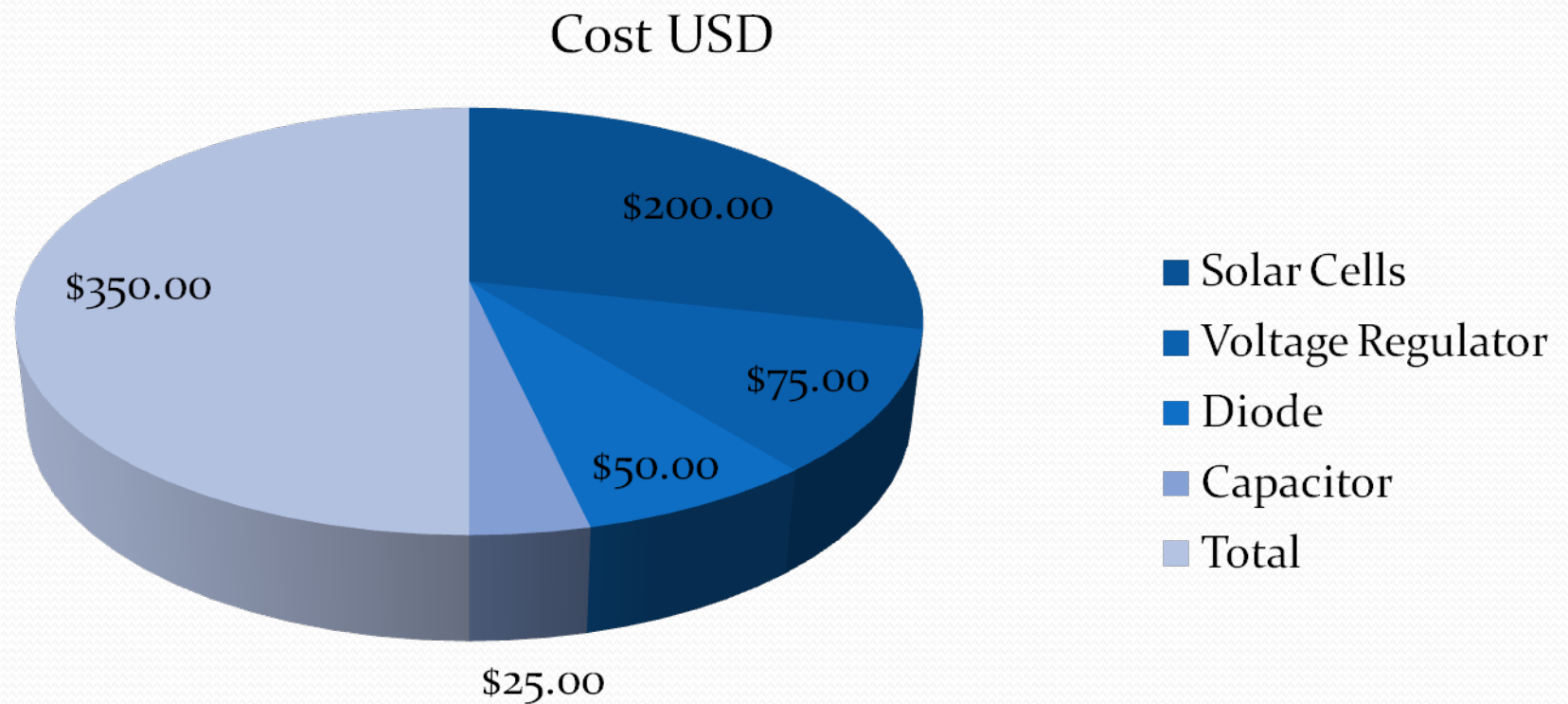

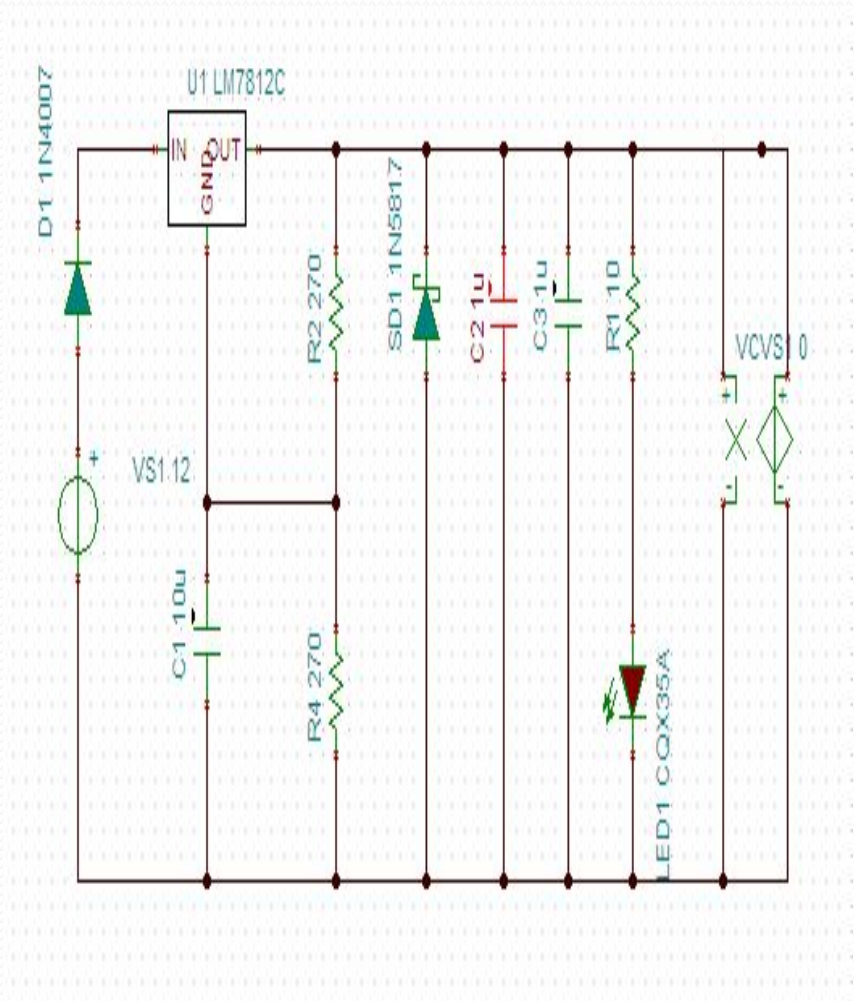
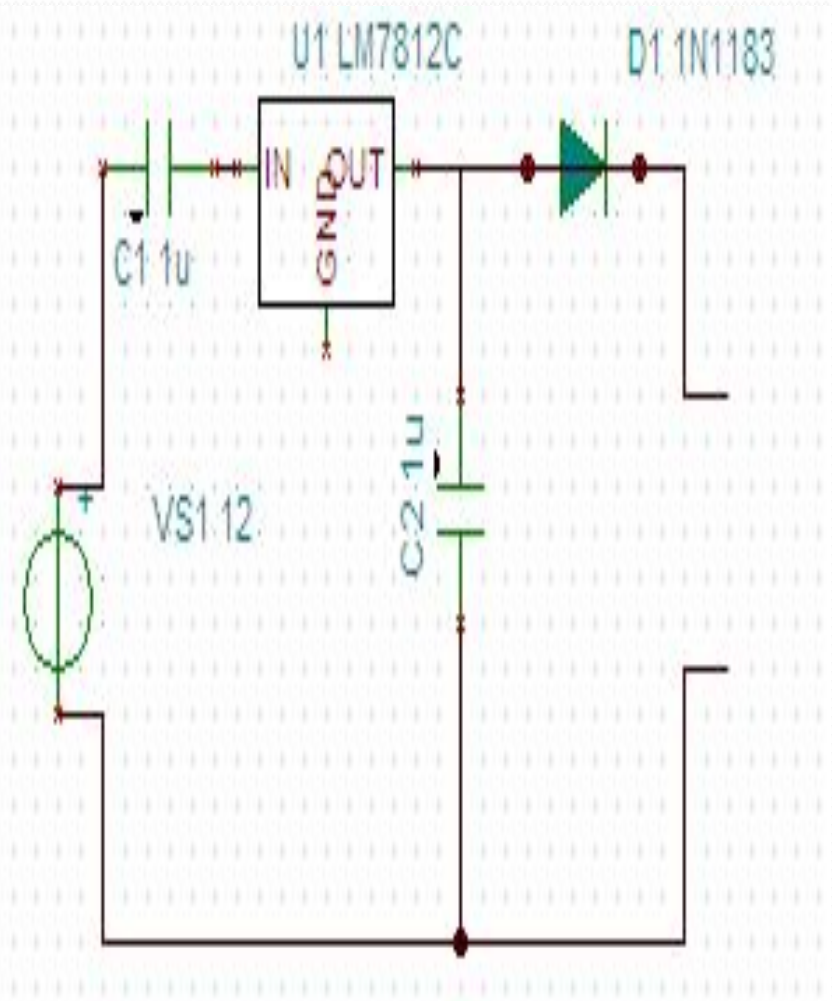

Noname - Schematic Editor

File Edit Insert View Analysis Interactive T&M Tools Help

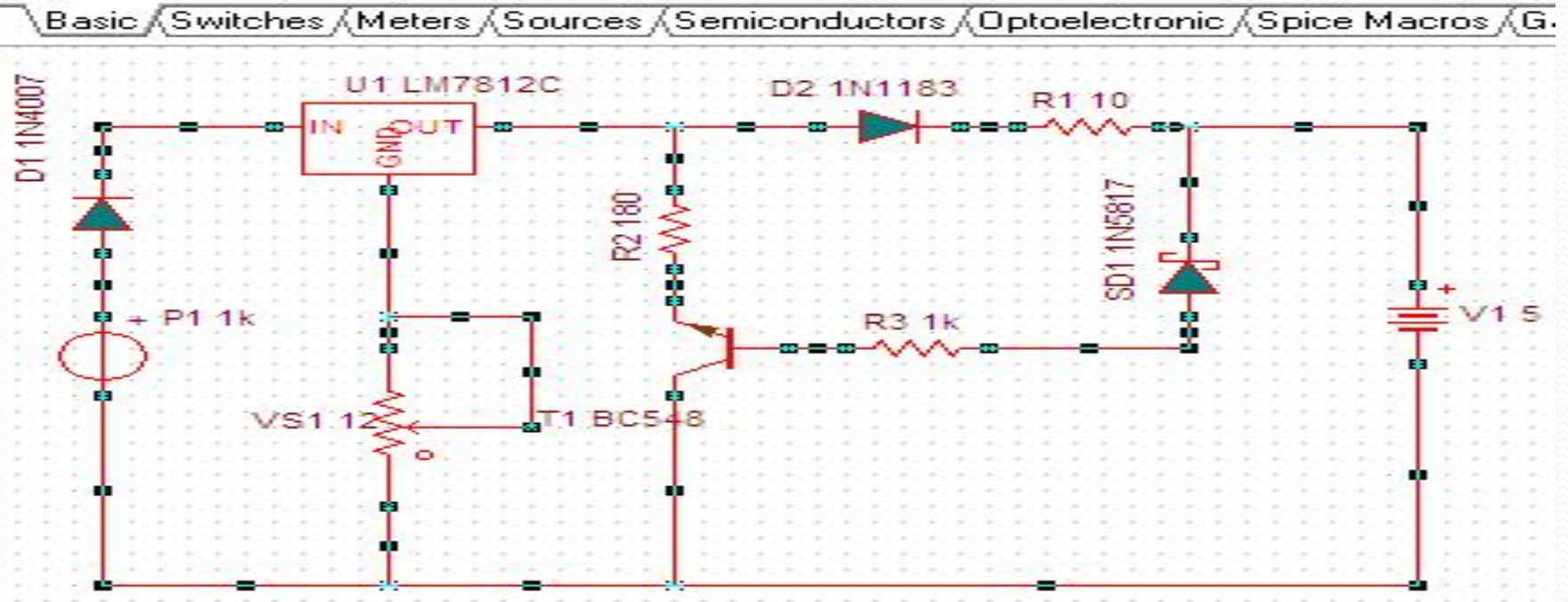
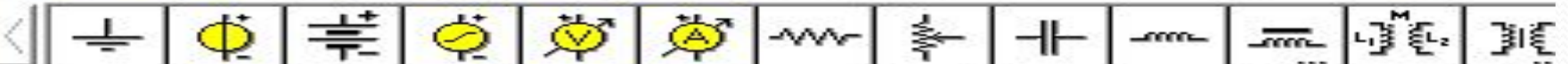

Methodology Used

Analyse

- Proposal
- Project schedule

Plan

- resource and communication plan

Design

- In this stage of the project a software tina was used in designing of the circuit.

Development

- Diode – prevent the flow back of current
- Voltage Regulator – 7812 provide the necessary current for the battery need to charge.
- Capacitor

Implement

- Testing

Software & Tools for Implementation

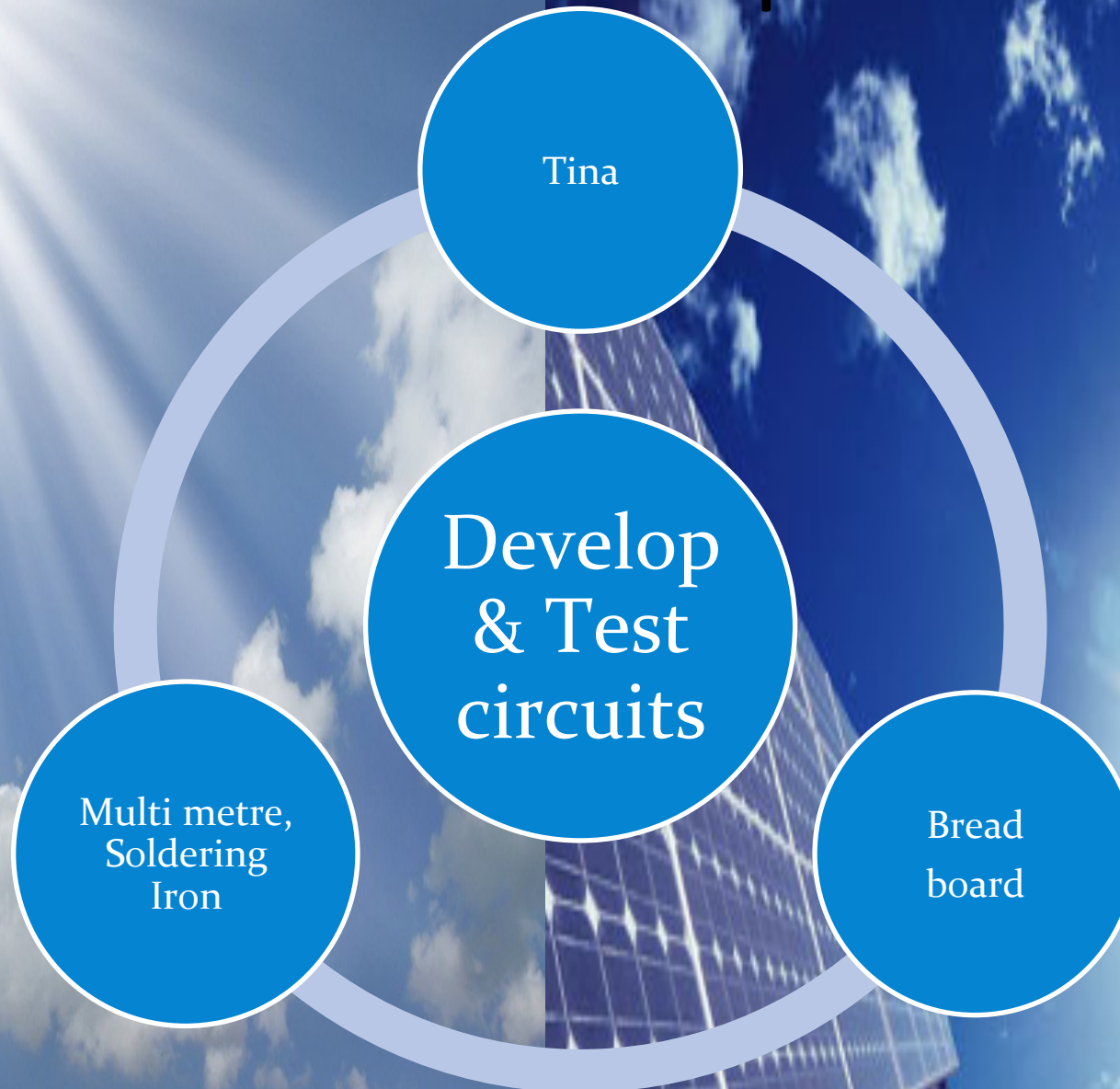

Future Scope

Reduce the size of the prototype so that it can be more portable.

To extend the idea to business that may be interested in funding of the further development of this project.

Full
version

```
graph TD; A[Reduce the size of the prototype so that it can be more portable.] --> C((Full version)); B[To extend the idea to business that may be interested in funding of the further development of this project.] --> C;
```

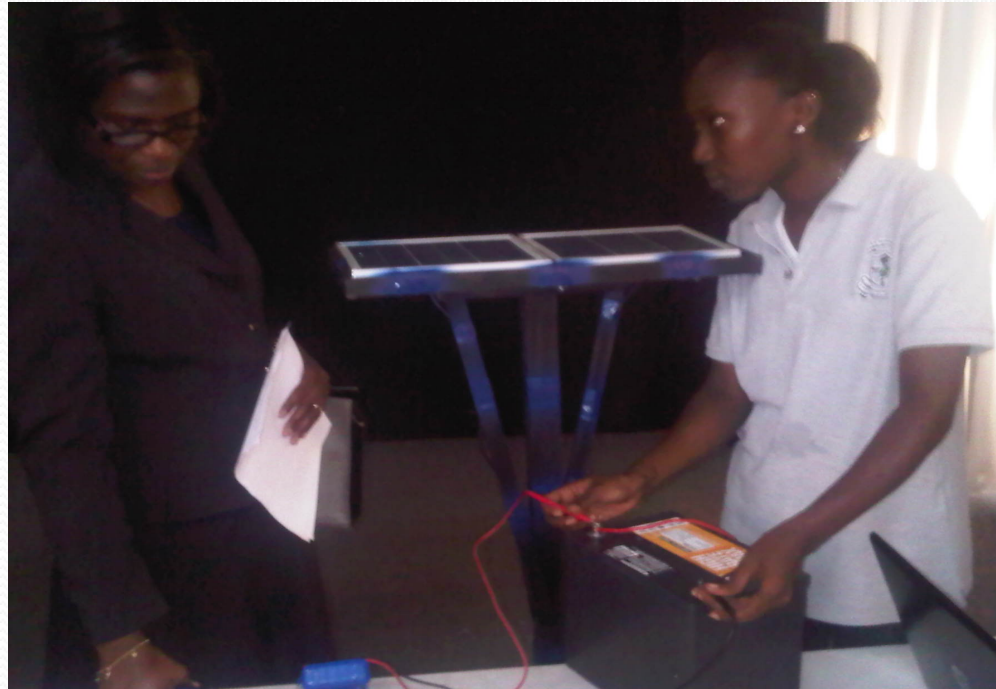



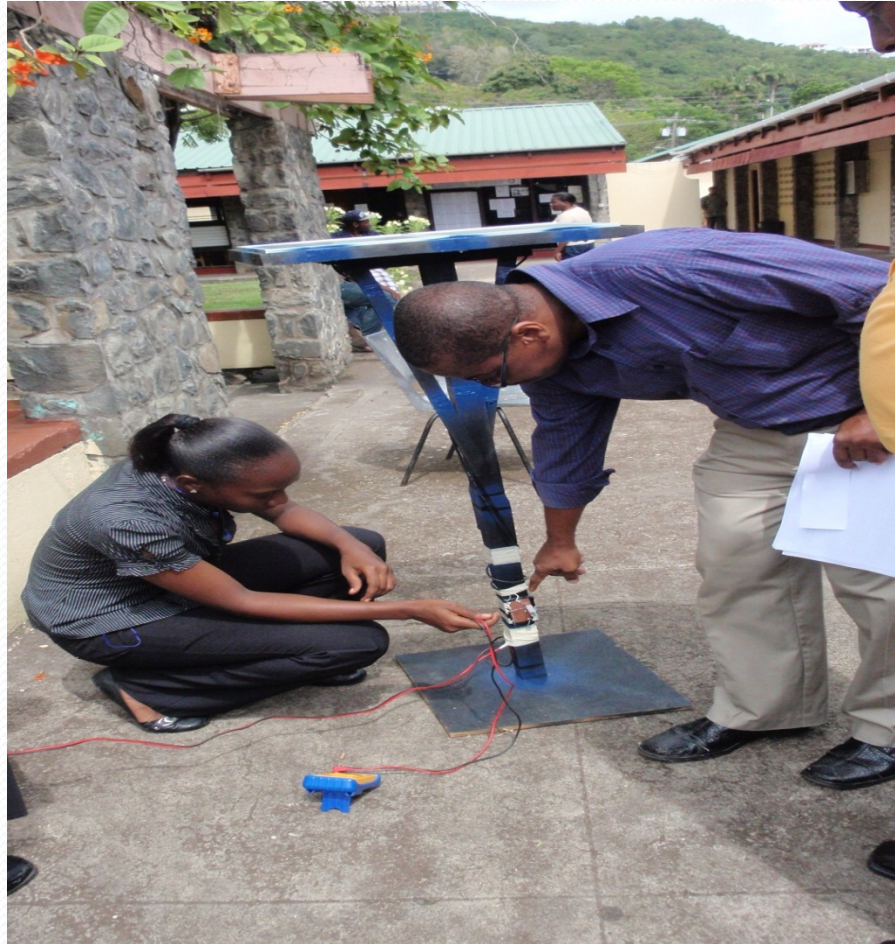











Conclusion

It can be concluded that this project was successfully executed despite the limitations outlined earlier.

It was an innovative and creative idea.

Relative information regard electronics and technology integration was acquired.

It effectively solved many of the social and economic problems identified.

Acknowledgment

- Mr. A. Hypolite *Electronic Lecture*
- Mr. B. Bethel *Student Project Lecture*
- Mrs. K. Thompson *Chair and lecture*
- Class Mates *CSE 2B*
- To all those who helped in the development of this project.